

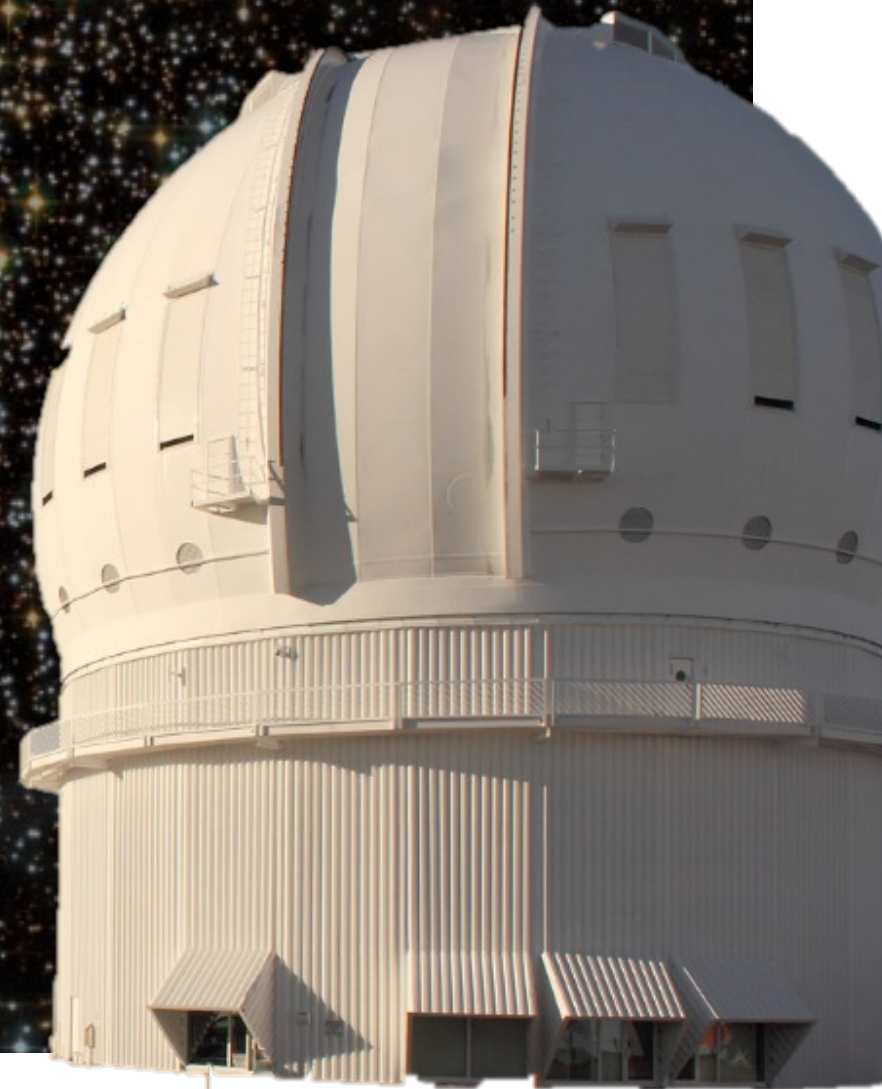

CFHT *on the Future*

Presentation Outline

- * **CFHT Strategic Matters**
 - * Associate Partners
 - * 2016 Users' Meeting
- * **New Instruments**
- * **MSE Update**
- * **Maunakea Conflict**



Subaru Users Meeting
January 2016



- ✧ **Next CFHT Triennial Users Meeting will be held in Nice, France May 1-4**
- ✧ **Range of topics including**
 - ★ **Plans for Large Programs starting 17A**
 - ★ **New instrumentation (SITELE, SPIROU)**
 - ★ **MSE**
 - ★ **Future of Maunakea**



Associate Partner Status

- * **CFHT has Associate Partnership agreements with several national agencies**
 - * Collaborative agreements which enable joint work on instrumentation, access to CFHT, funding for instrumentation, MSE, visiting scientists, etc.
- * **Agreements with -**
 - * China/NAOC extends through 2018B - up to 15 nights/semester
 - * Taiwan/ASIAA extends through 2016B - up to 10 nights/semester, will seek renewal later this year
 - * S. Korea/KASI - MOU expired but remain interested in collaborating in the future
 - * Brazil agreement renewal on hold pending resolution of funding and legal issues in Brazil
- * *CFHT remains interested in pursuing an umbrella agreement with Asian astronomy agencies via CFHT Corp. - EAO Corp. MOU*
 - * *Would in principle open many doors, including with Japan...*



SITELLE Arrives at CFHT

Filter Wheel & Calibration

Carbon Fiber Support Structure

Telescope Interface Plate

CCD

Control Electronics

CCD

Beam Splitter

Precision Scan Mirror

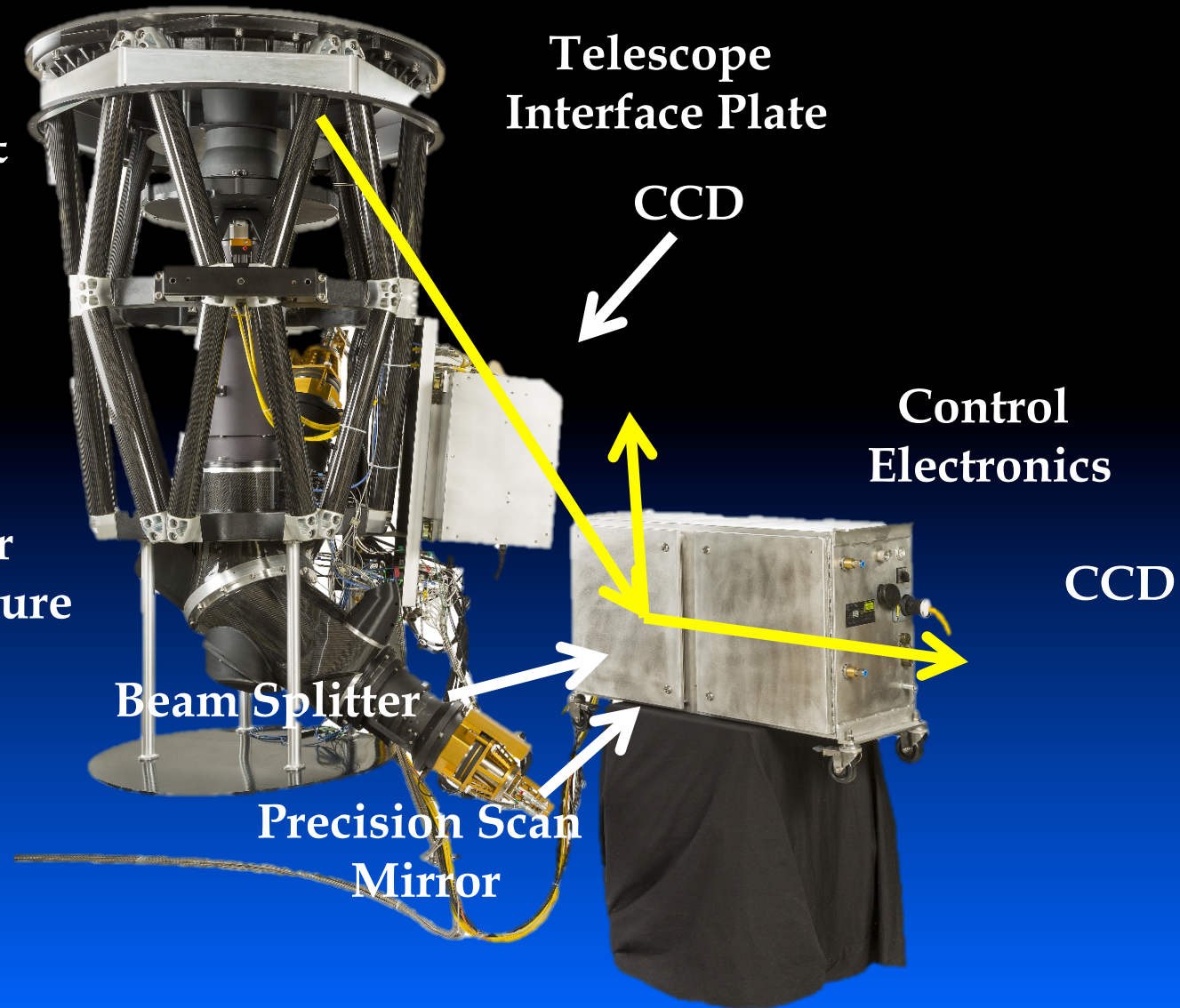



SITELLE's Long Journey from Quebec



SITELLE Mounted on CFHT



SITELLE Commissioning

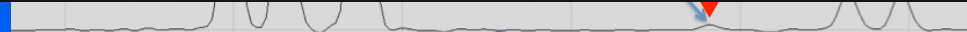
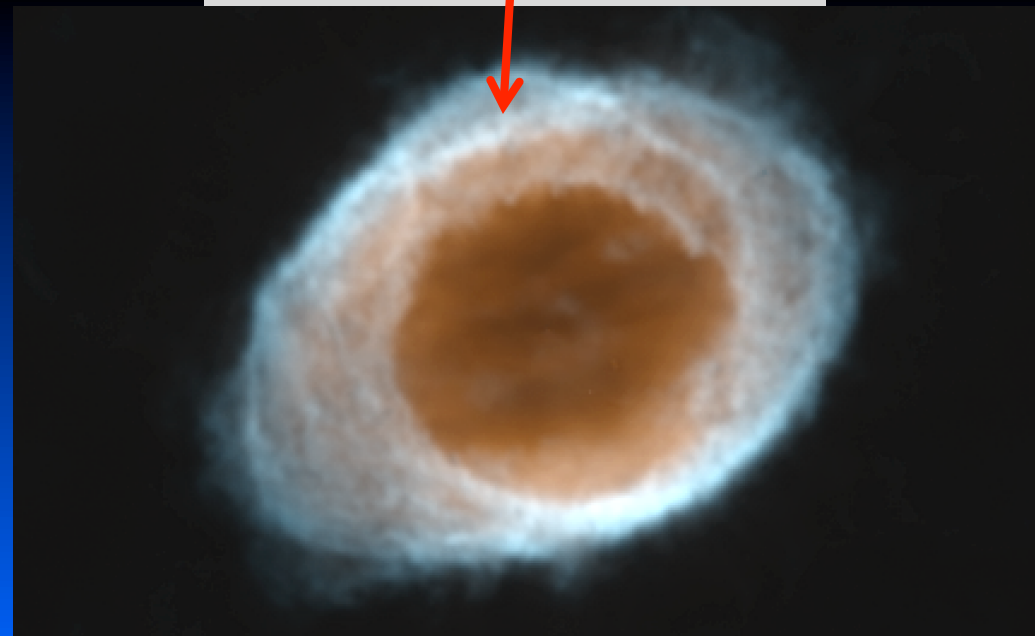
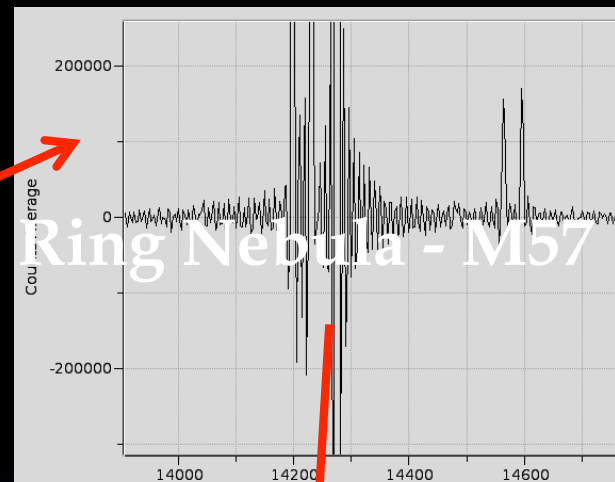
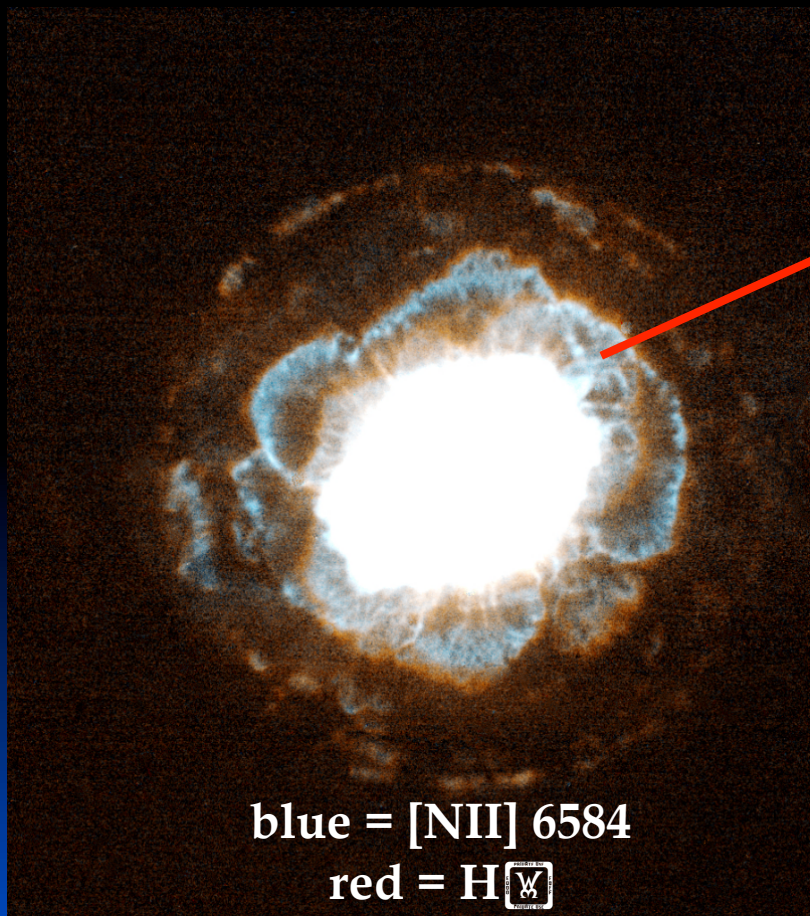



SITELLE Commissioning

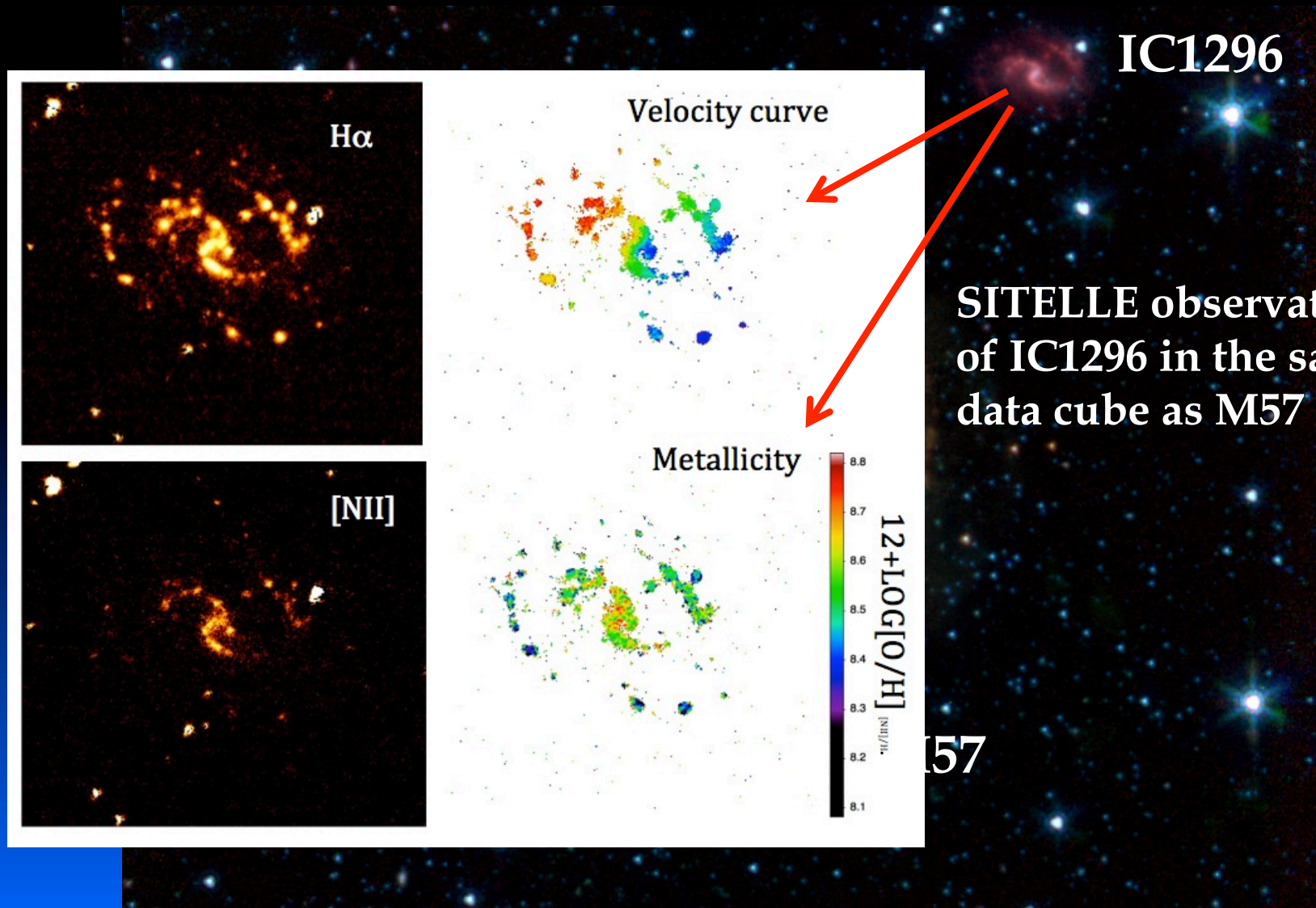



SITELLE Commissioning

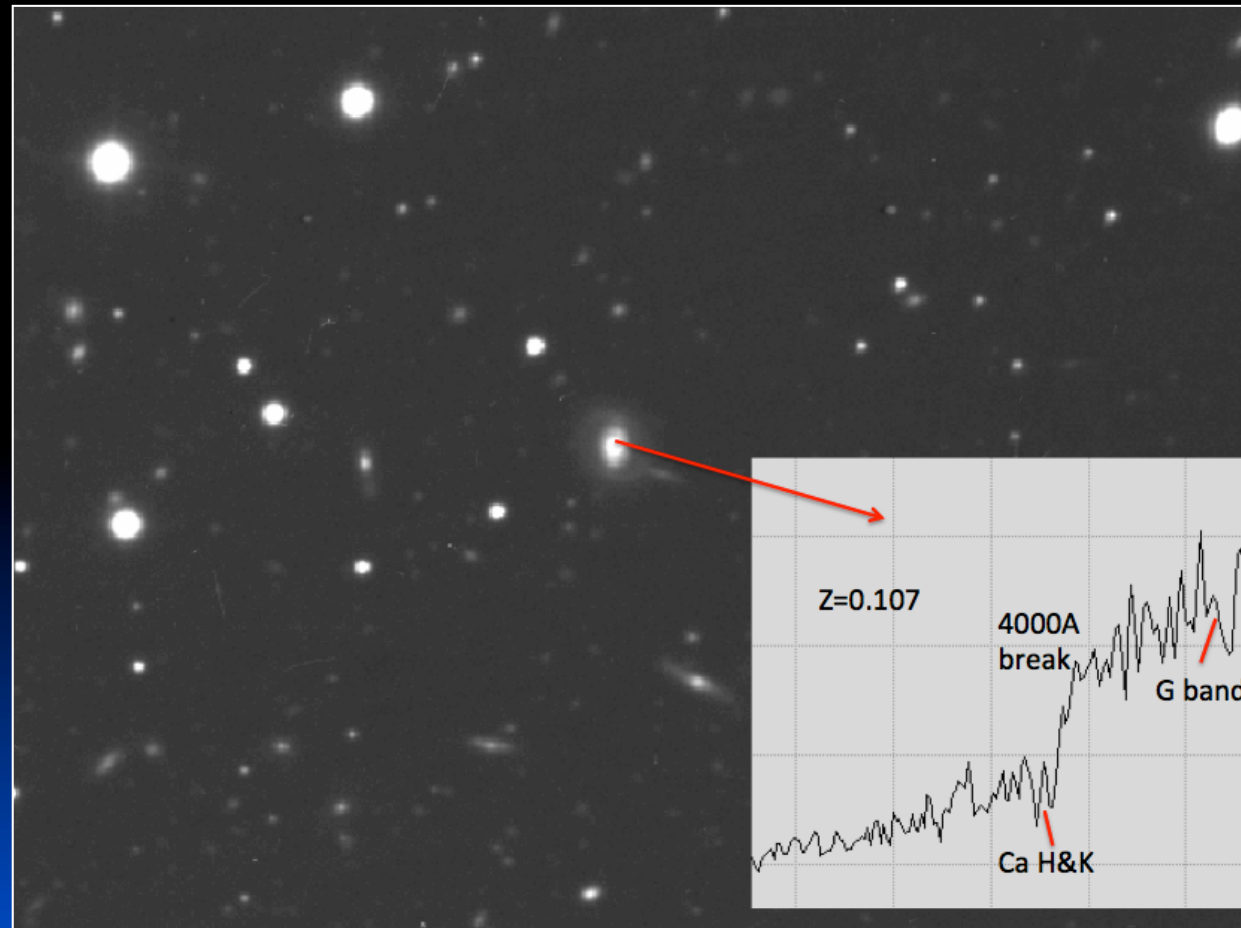

Abell 2261, "intruder", a spiral galaxy at redshift $z \sim 0.1$. Note the absorption lines characteristic of solar-type stars, from the old stellar population.



Next Steps with SITELLE

- * SITELLE has been offered as part of CFHT's 2016A Call for Proposals
- * Science Verification recently completed
 - * Commissioning data extensive enough to "tune" ETC and support proposal generation process

- * D
- * q
- * W
- * P
- * q
- * tr

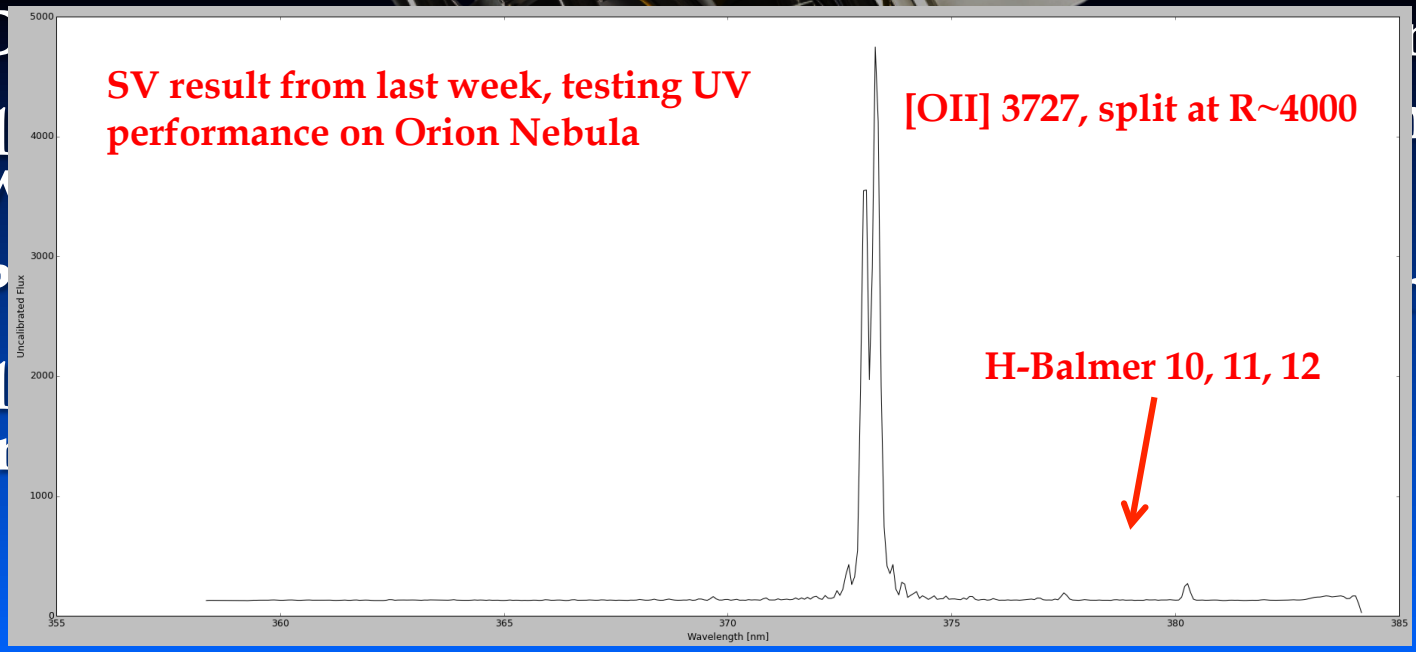

nd
n
mage



SPIRou

Cassegrain Unit

- * Deployed at CFHT f/8 focus
- * NIR high speed guide camera for tip/tilt compensation
- * Fiber links to calibration sources and spectrograph
- * Atmospheric Dispersion Compensator
- * Thermo-electrically cooled stop
- * High performance Rhombs and Wollaston prism

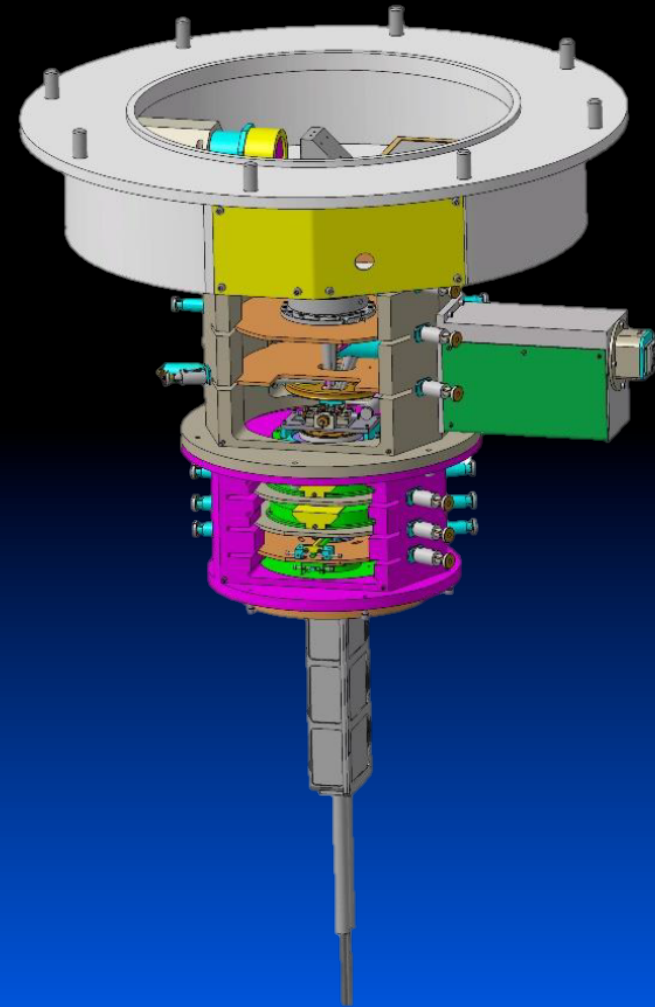



SPIRou

Spectrograph Unit

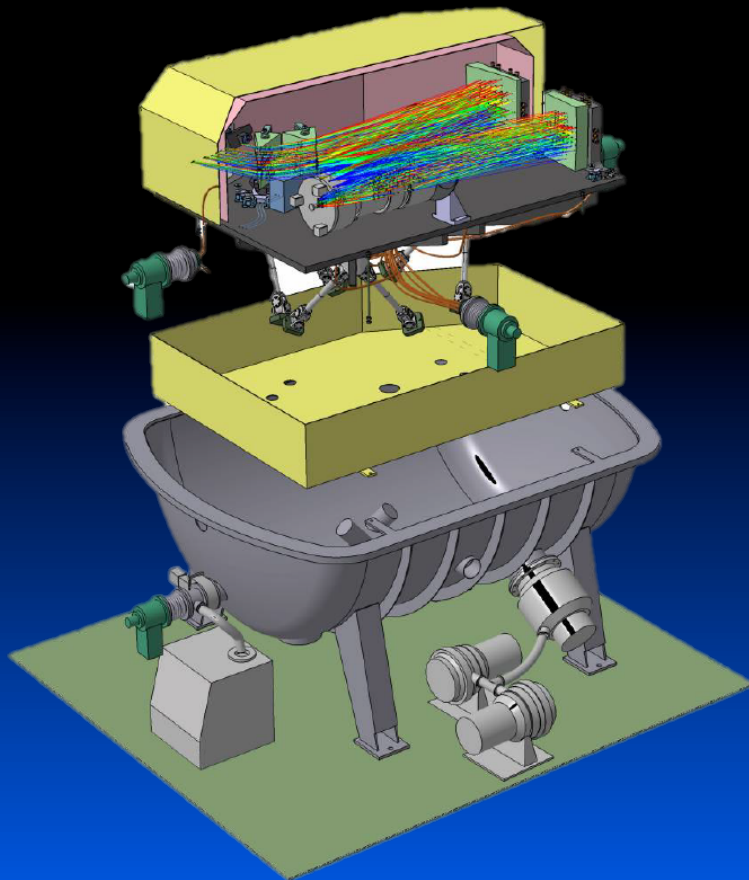

- * Deployed in CFHT Coude room
- * Ultra stable cryogenic temperature control
- * R2 echelle grating fed by reflective image slicer and collimator
- * H4RG 1-2.5 μm science detector
- * Prism cross-disperser yielding YJHK single shot spectra at $R \sim 70\text{K}$ with ~ 1 m/s stability



SPIRou

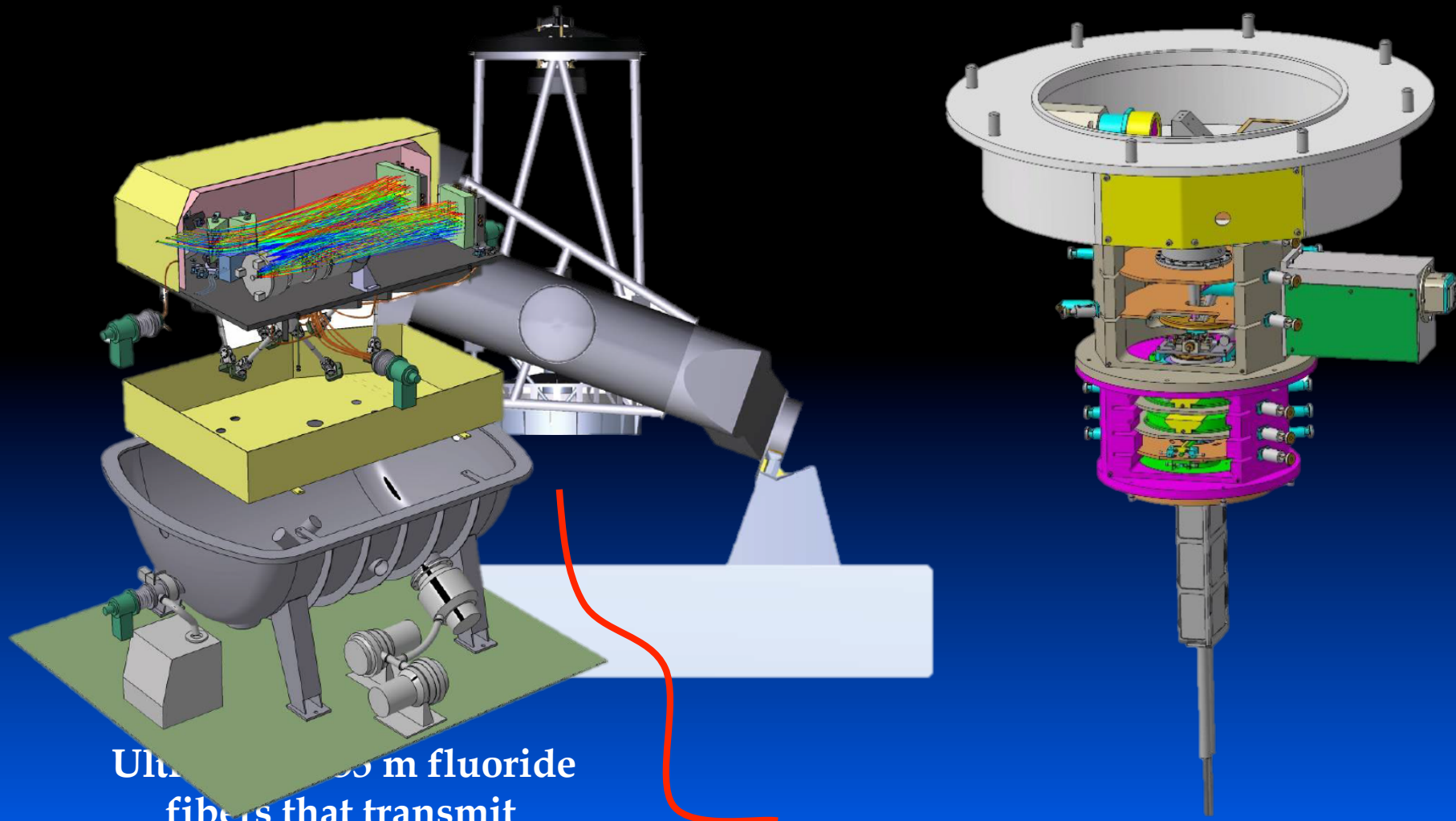

Ultra-long 50 m fluoride
fibers that transmit
through 2.5 μm



SPIROu Under Fabrication

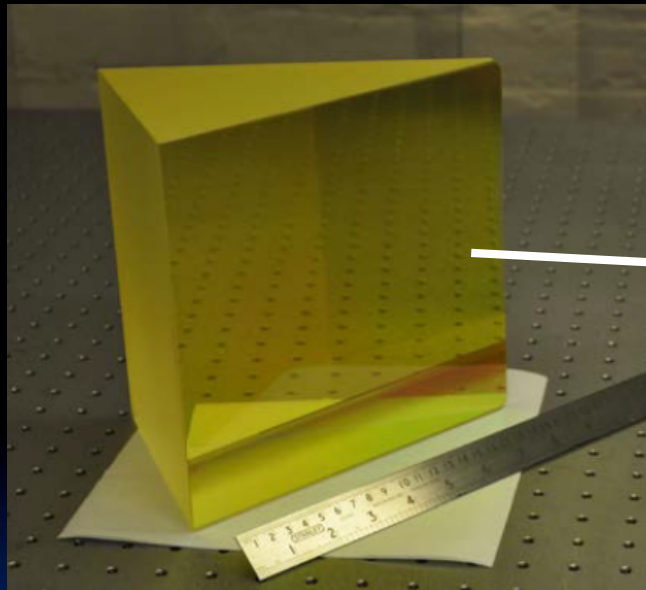

**Infrasil
Prism**

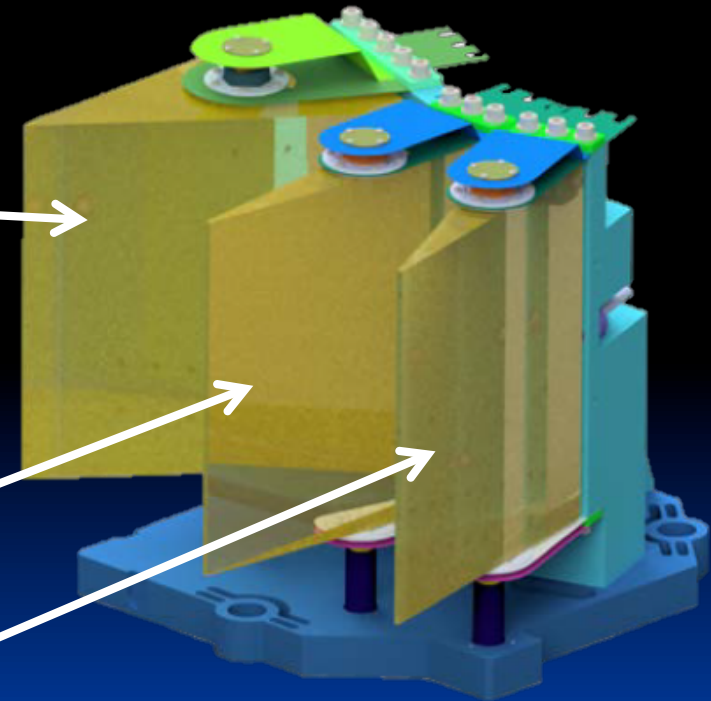

Triple prism cross disperser

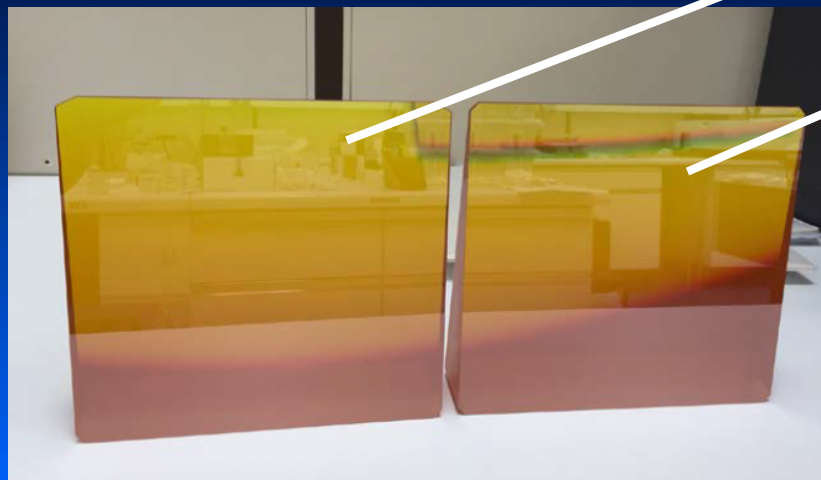

**ZnSe
Prisms**



SPIRou Under Fabrication

SPIRou Vacuum Jacket

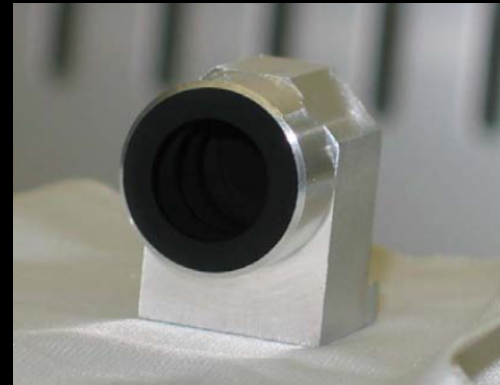

TE-Cooled Pupil Stop



**SPIRou NIR
Guide Camera
Being Tested at
CFHT**

**Cassegrain
Opto-mechanical
Assembly**

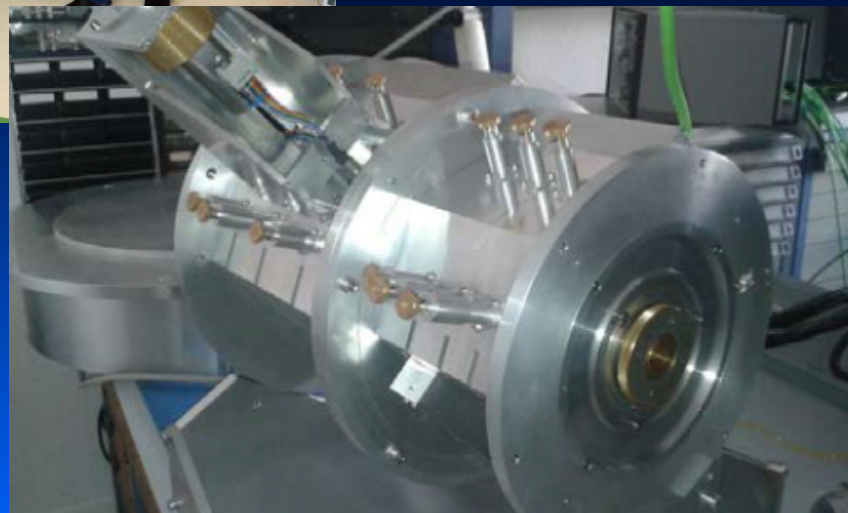



Key Next Steps for SPIRou

- * **Finalize acquisition of e-grade H4RG from UH to support lab I&T phase of SPIRou development**
 - * CFHT will purchase and loan to SPIRou project
 - * Procurement underway but complex
- * **Purchase science grade detector for SPIRou from Teledyne**
 - * Quote received for two s-grade (SPIRou + NIRPS), 2 e-grade, ASIC assemblies, cables
 - * Contracting effort for procurement imminent
- * **Package all 3 detectors at GL Scientific**
 - * Contract under review now by all parties
- * **ITAR TAA (Technical Assistance Agreement) completion imminent**
 - * Effective once signed across SPIRou team



GRACES

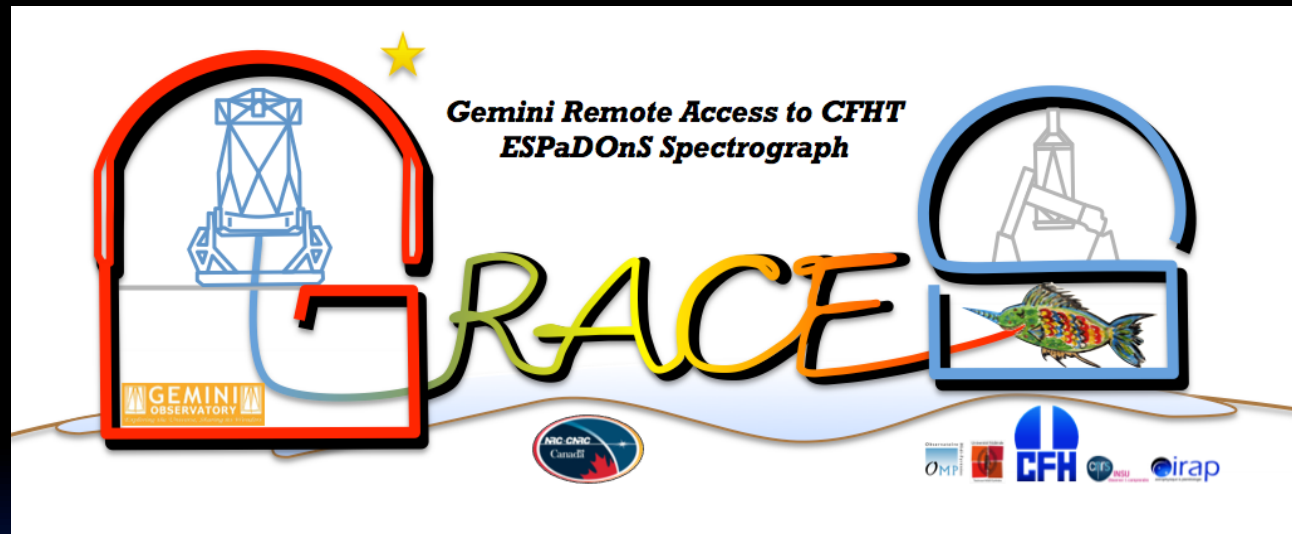

- * Fiber link enabling feed of CFHT's high-resolution optical spectrograph Espandons from Gemini
 - * Resolution up to $R \sim 67K$ (star only) or $R \sim 40K$ (star+sky)
 - * Optimized for use in the $\sim 600 - 900$ nm range
 - * 1.2" fiber aperture on sky
- * Data archived and distributed via Gemini
- * Time exchange program in place with start of science operations in 15B



GRACES

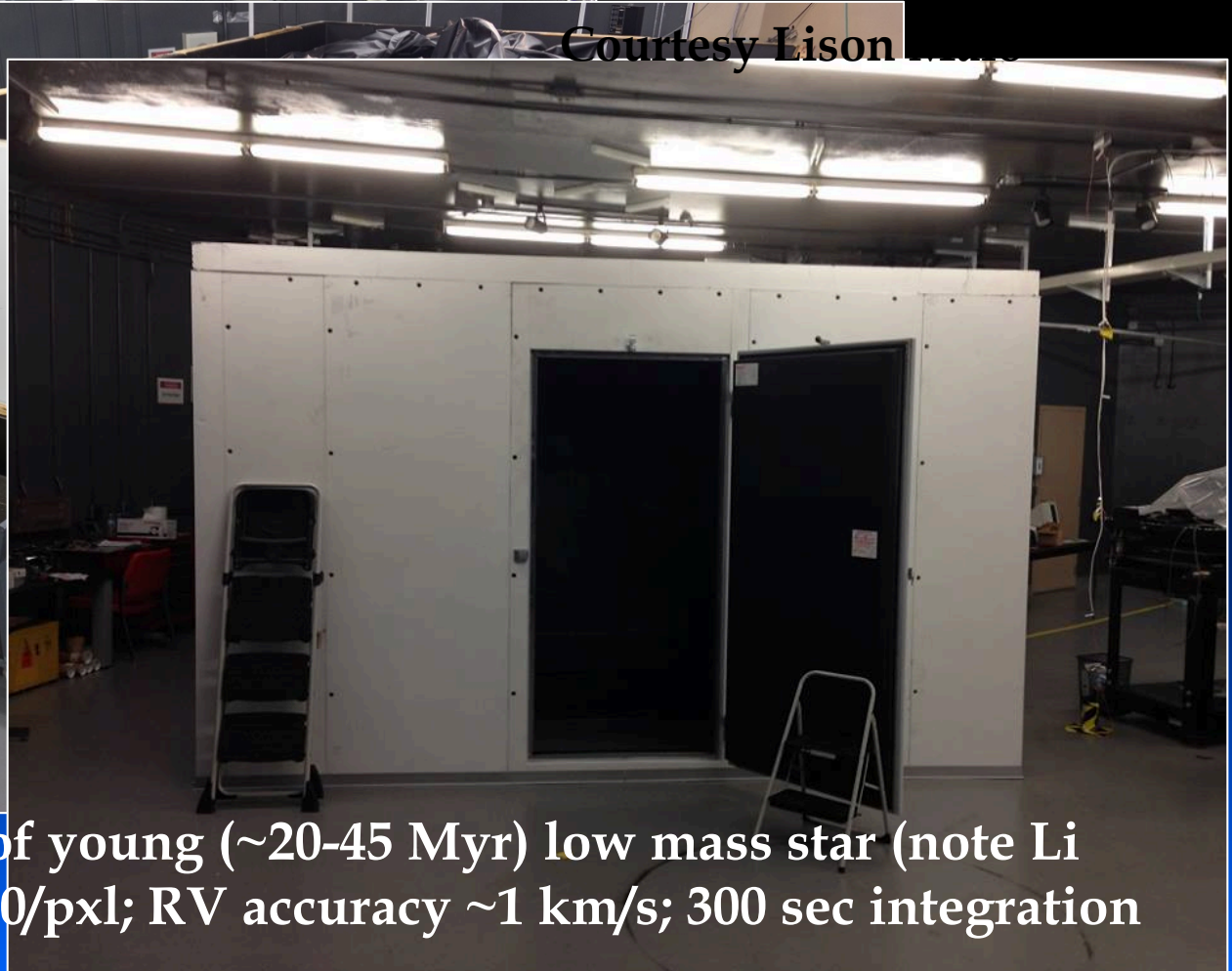
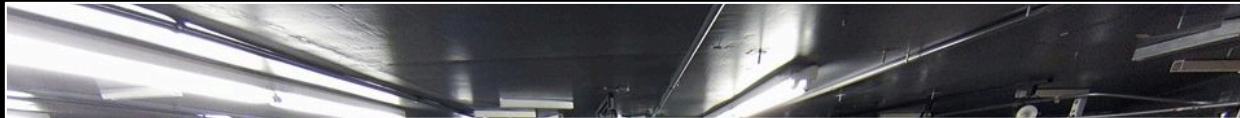

GRACES spectrum of young ($\sim 20\text{-}45$ Myr) low mass star (note Li absorption); SNR $\sim 50/\text{pxl}$; RV accuracy ~ 1 km/s; 300 sec integration



Call for Large Programs

Starting in 2017A, ~2/3 of CFHT time

will be dedicated to large programs
will take nominally ~5 years

Total Impact per Telescope

2011 - Courtesy D. Crabtree

Strategy is to split program into 2 halves and dynamically manage them, factoring in SPIRou availability, demonstrated performance, MSE status, etc.

Call for Proposals released last summer describing goals, process, schedule, etc.

This greater reliance upon surveys is expected to -

- Help keep CFHT competitive through this decade
- Help secure commitments to operate CFHT, and
- Function as a segue to MSE...

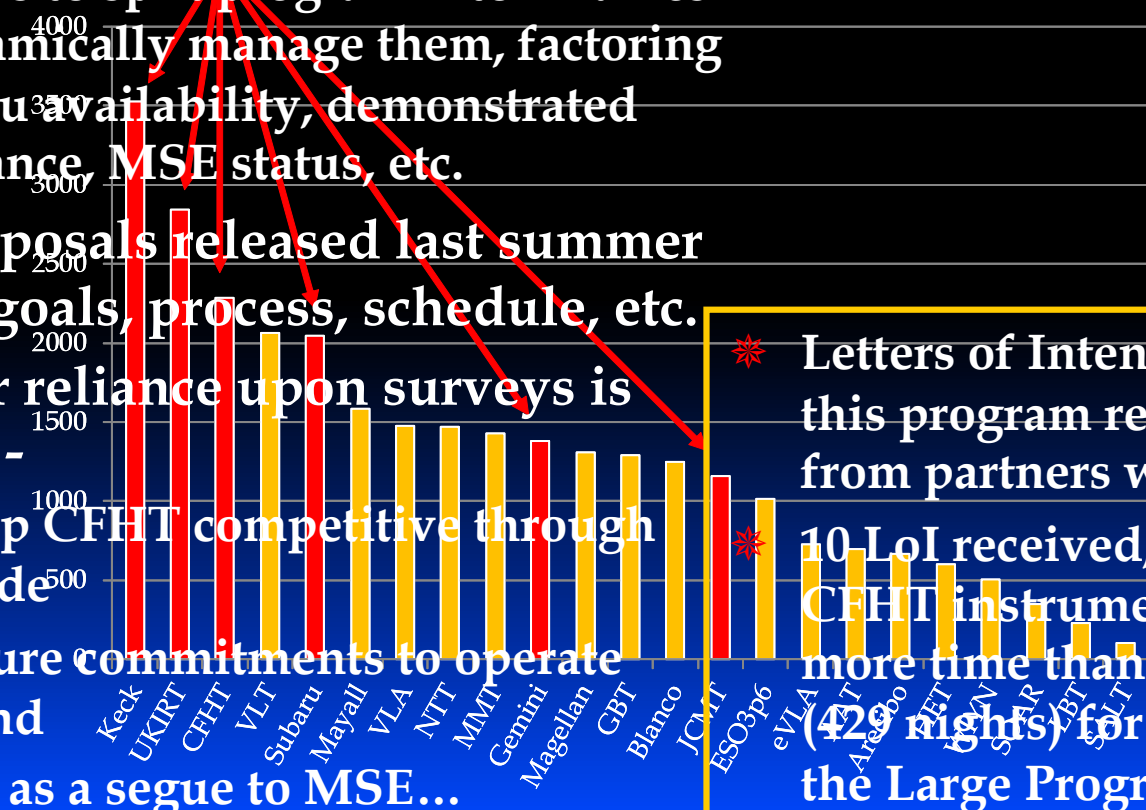

Letters of Intent to participate in this program recently received from partners worldwide

10 LoI received, requesting all CFHT instruments, seeking ~3X more time than is being offered (429 nights) for this first part of the Large Program execution



MSE Top Level Science Requirements





MSE Observatory Science Requirements Document

01.01.00.001.REQ
Version: A

Status: *Released*

2015-10-23

Prepared By:		
Name(s) and Signature(s)	Organization	Date
 Alan McConnachie	MSE Project Scientist	2015 Oct 21
Approved By:		
Name and Signature	Organization	Date
 Rick Murowinski	MSE Project Manager	2015 Oct 23

Accessible sky
Etendue = $A \times \Omega$
Modes
Wavelength range
Spectral resolution
Multiplexing
Spectral windows
Sensitivity
Velocity precision
Relative spectrophotometry

$\lambda < 1.55 \mu\text{m}$
Area (square degrees)
Mode
Wavelength range (μm)
Spectral resolution
Multiplexing
Spectral windows
Sensitivity
Velocity precision (m/s)
Relative spectrophotometry



MSE vs. CFHT

Use of the "10% Rule"
for existing structures
vastly simplifies MSE
permitting vs. TMT

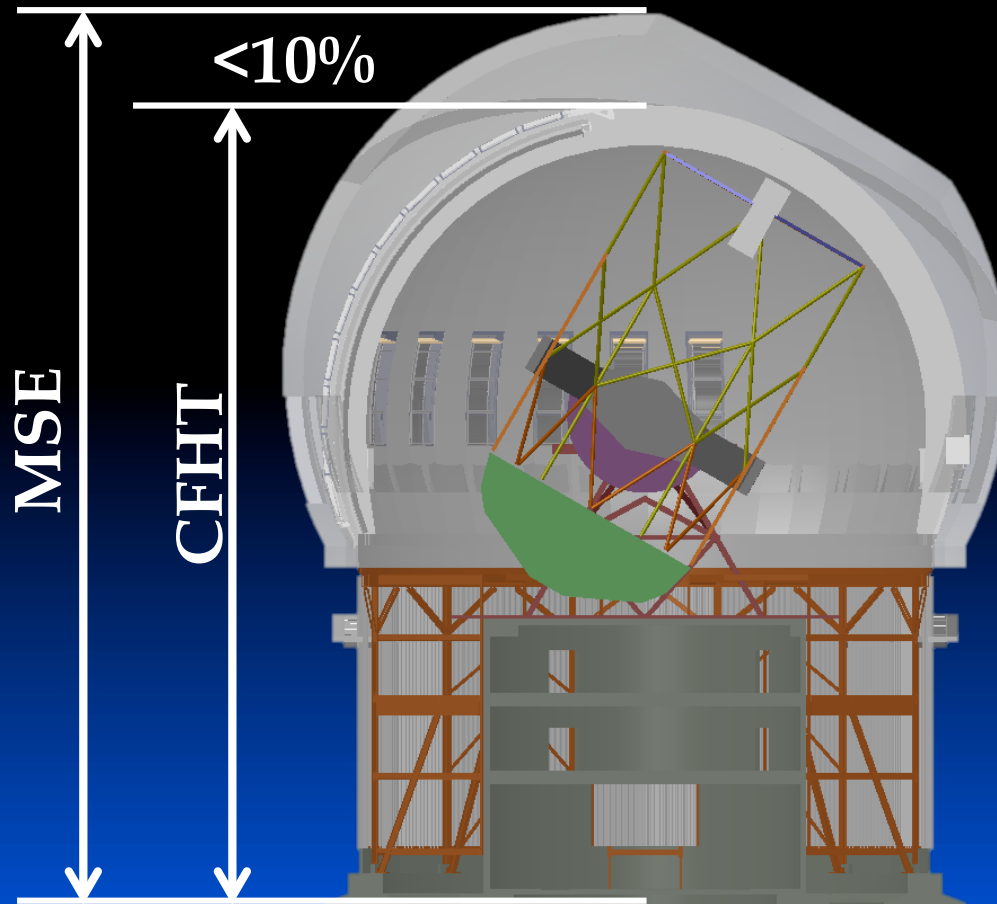



2015 MSE Project Activity

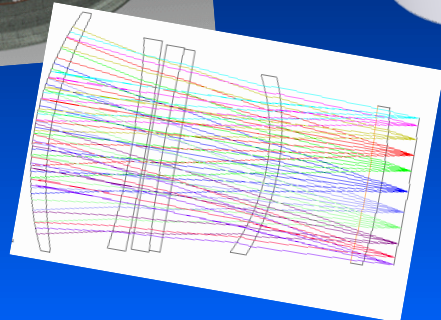
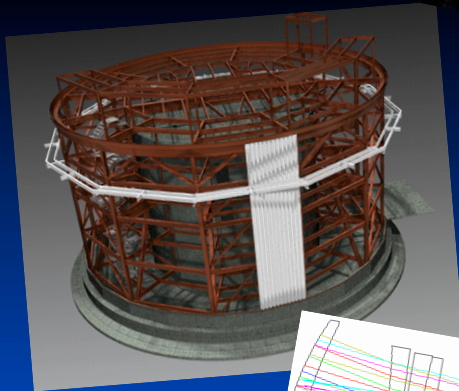
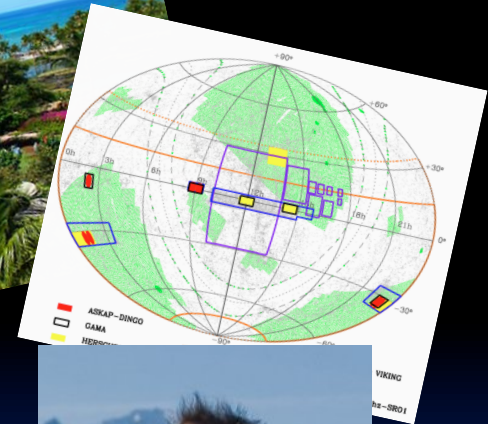
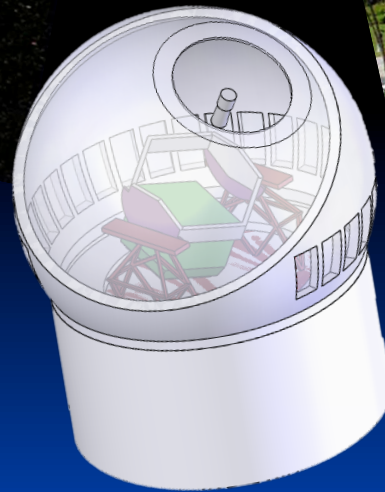

Kei Szeto
MSE Project Engineer



Nicolas Flagey
Systems Scientist

MAUNAKEA SPECTROSCOPIC EXPLORER (MSE)
TECHNOLOGY WORKSHOP
Nanjing, China, April 1 - 3, 2015



MAUNAKEA SPECTROSCOPIC EXPLORER (MSE)

Paris, France, October 14-16, 2015

~~Nanjing, China, April 1-3, 2015~~

TECHNOLOGY WORKSHOP

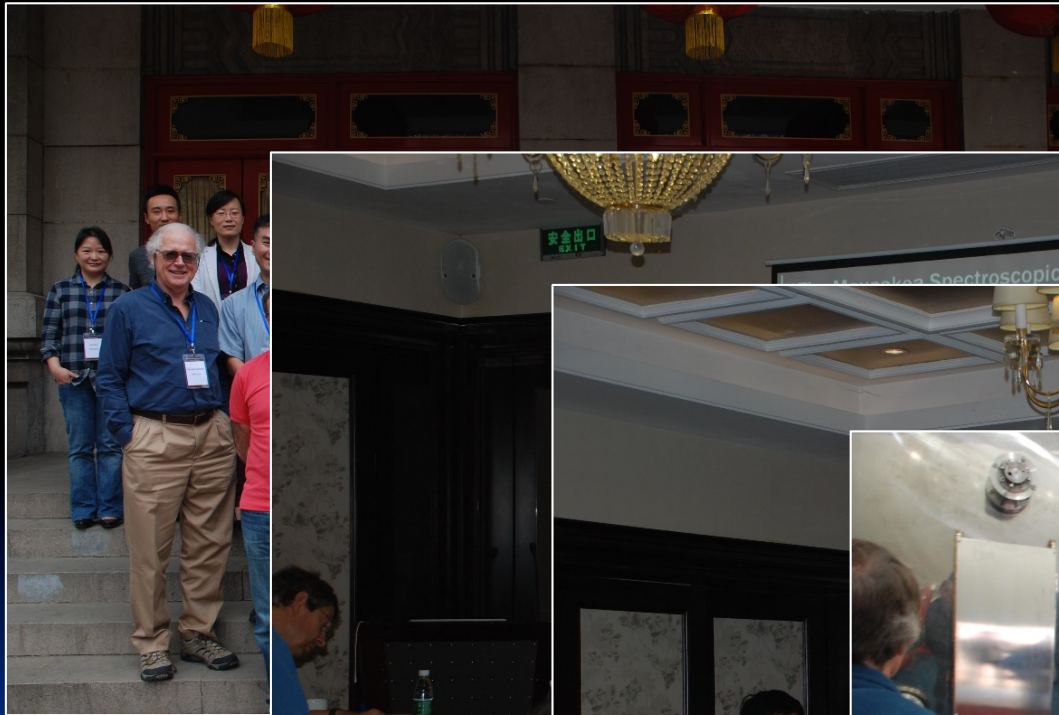



MAUNAKEA SPECTROSCOPIC EXPLORER (MSE)

Paris, France, October 14-16, 2015

~~Nanjing, China, April 1-3, 2015~~

TECHNOLOGY WORKSHOP





MSE Science Conference

(Waikoloa, July 2015)





MSE Project Office Work - 2016

4 Proposed Budget for 2016

The proposed budget for MSE for 2016 is detailed in the separate document MSE Detailed Budget Projections – 2016. The requested amount for 2016 is **\$1,807,184**.

In that budget we propose to augment the two PO full time staff with one new staff and a to-mechanical engineer starting in April. Additionally the budget funds contracts for the purchase of a part-time manager, an optical consultant (Paolo Spina) and a consultant in fiber optic technology (Eric Williams). Project Scientist A. M. ... will continue to be provided in-kind from NRC-H, and ... will continue to be provided in-kind from GEPI, France.

The budget also funds 20 projects for a number of contracts. Those over \$50K are:

- Fiber positioner conceptual design,
- Enclosure conceptual design,
- Telescope mount conceptual design,
- Enclosure flushing study,
- Geotechnical study of soil performance beneath pier,
- Strategic communications support.

APPROVED

The conflict over TMT last year was unprecedented in many ways, revealing rifts in the Hawaii community that are as complex as they are deep. Steeped in symbolism, the future of Maunakea for the people of Hawaii portends in important ways the future of 21st century astronomy.



Classic "3 Legged Stool" Situation



Sustainability through balance

Science



Culture

We are all stewards of this sacred mountain

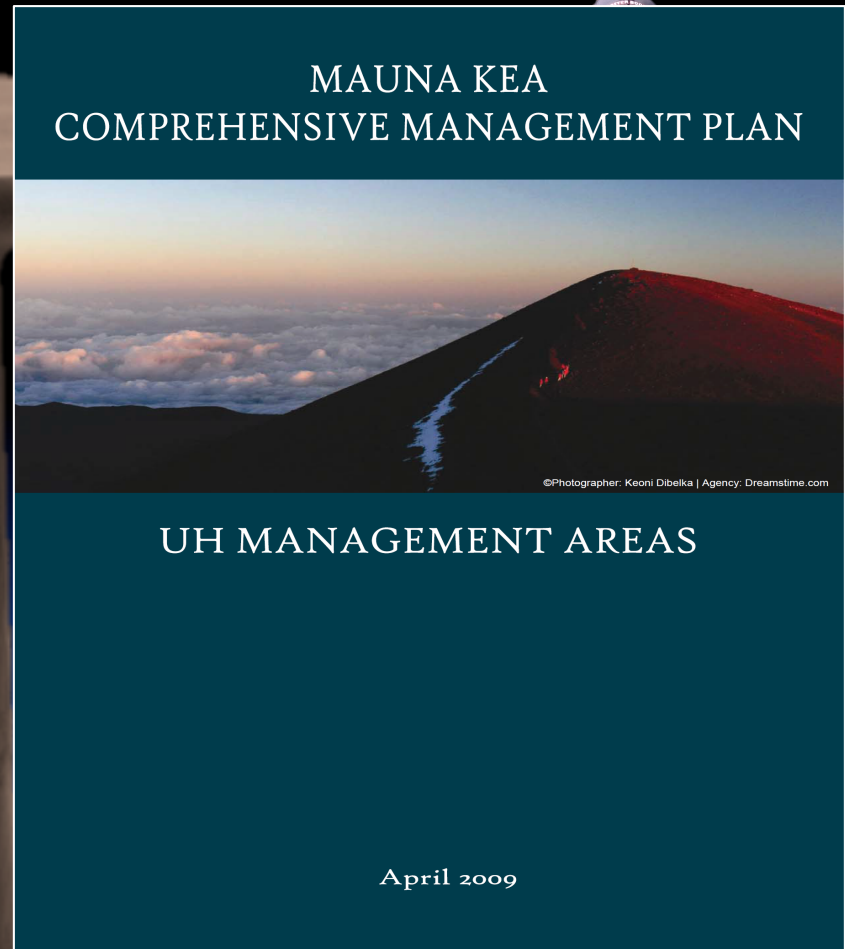



Community Meetings



Focusing On Our Message

JOURNEY through the UNIVERSE

Extends to Honoka'a and beyond...

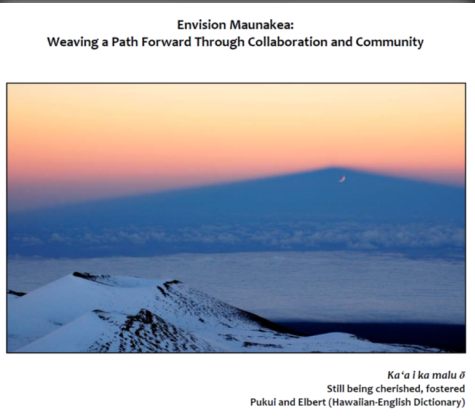

Envision Maunakea



Maunakea Scholars



- * **Third Saturday of each month (starting Jan. 16), free tours of 2 telescopes given to Hawaii residents**
- * **Tour includes -**
 - * **Lunch at Halepohaku**
 - * **Cultural/Environmental training**
 - * **Transportation from VIS to/from summit**
 - * **Opportunity to see 2 telescopes, talk to staff, etc. by 24 residents in each tour**
- * **KOE Collaboration -**
 - * **Imiloa** reservation system, cultural components
 - * **UH/MKSS** rents 4WD vans
 - * **OMKM** rangers (safety) and environmental education
 - * **VIS** interpretive guides and logistics
 - * **Bennet** Group media support, custom signage, brochures, etc.
 - * **Moore** Foundation funding
 - * **MKO** staff provide summit tours



Mahalo Letter from the Maunakea

**Observatories to President Obama
The Kama'aina Observatory Experience
Published in Newspapers Statewide
is the embodiment of core philosophies
in the CMP and expressed by the
Maunakea Observatories since the
conflict arose last year.**

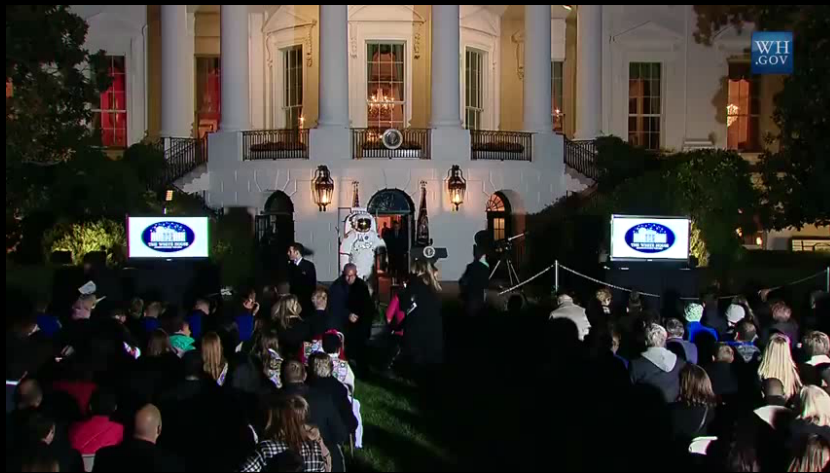

White House "Astronomy Night" (Oct. 2015) during which President Obama announced the formation of KOE

By demonstrating to the public the melding of cultural, environmental, and scientific interests on Maunakea, in a highly memorable "experience", we build support and motivate the public to share theirs



Inaugural Tour – January 16



Local TV Coverage

Video by



Cultural/Environmental Program



CFHT & Gemini Tours



“Maunakea Fund”

- ✧ TMT set many important precedents including provision of significant funding for education and workforce development
 - ✧ TMT now providing \$1M annually to THINK Fund and \$1M annually to workforce development
 - ✧ THINK Fund administered by Hawaii Community Foundation (HCF)
- ✧ CFHT/MSE has created a new “signature fund” with HCF, in the effective 2016, at the rate of \$100K/yr



- ✧ CFHT's commitment to our community at a crucial time
THINK Fund Advisory Committee



Mahalo...

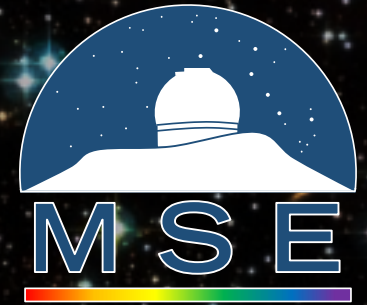

- ✧ The Maunakea Observatories remain committed to ensuring a bright future for Hawaii astronomy well into the 21st century through a variety of initiatives and relentless engagement of the Maunakea conflict
- ✧ The path forward involves many steps, chief among them –
 - ✧ A unified voice and vision from the Maunakea Observatories for the future of Maunakea
 - ✧ Coordinated, repeated calls for the melding of culture, environment, and science on Maunakea
 - ✧ Unabashed support for community based management of Maunakea (OMKM, CMP, etc.)
- ✧ The situation is serious but working together, we can resolve it...

